

(19)  **Europäisches Patentamt**
European Patent Office
Office européen des brevets



(11) **EP 1 003 066 A1**

(12) **EUROPEAN PATENT APPLICATION**

(43) Date of publication: **24.05.2000 Bulletin 2000/21** (51) Int Cl.7: **G02F 1/1339, G02F 1/1333**
(21) Application number: **99308932.5**
(22) Date of filing: **09.11.1999**

(84) Designated Contracting States:
AT BE CH CY DE DK ES FI FR GB GR IE IT LI LU MC NL PT SE
Designated Extension States:
AL LT LV MK RO SI
(30) Priority: **16.11.1998 JP 32460598**
(71) Applicant: **Matsushita Electric Industrial Co., Ltd.**
Kadoma-shi, Osaka 571-8501 (JP)
(72) Inventors:
• **Egami, Norihiko**
Hirakata-shi, Osaka 573-1127 (JP)

• **Hokazono, Nobutaka**
Neyagawa-shi, Osaka 572-0043 (JP)
• **Inoue, Susumu**
Kadoma-shi, Osaka 571-0004 (JP)
• **Sumita, Shiro**
Ishikawa 921-8844 (JP)
• **Sakai, Naoto**
Sendai-shi, Miyagi 980-8579 (JP)
• **Matsukawa, Hideki**
Kanazawa-shi, Ishikawa 921-8161 (JP)
(74) Representative: **Rackham, Stephen Neil**
GILL JENNINGS & EVERY,
Broadgate House,
7 Eldon Street
London EC2M 7LH (GB)

(54) **Method of manufacturing liquid crystal display devices**

(57) A lower substrate (3) on which an adhesive (1) has been applied and a liquid crystal material (2) has been deposited is held fixedly by vacuum suction with a suction-holding mechanism (5) within a vacuum chamber (C). An upper substrate (6) held fixedly by vacuum suction with a suction-holding mechanism (7) is brought opposite to the lower substrate (3) with a predetermined spacing therebetween, and either or both of

the substrates is/are brought in proximity with each other for bringing the upper substrate into contact with the adhesive (1) or the liquid crystal material (2). Both substrates (3, 6) are then moved relative to each other in a direction parallel to the substrate surface for position alignment, and thereafter, the substrates are moved closer to and pressed to each other so that they are affixed together.

Fig. 1B

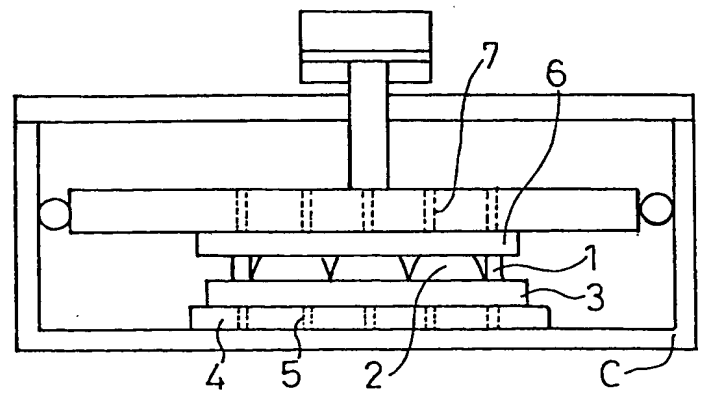

EP 1 003 066 A1

Description

[0001] The present invention relates to a method of manufacturing liquid crystal display devices that are used for the image display panel of a personal computer or a television.

[0002] A conventional method of manufacturing liquid crystal display device is described below with reference to Figs. 3 to 5.

[0003] A liquid crystal display device is constructed as shown in Fig. 3 such that two opposite and spaced substrates, a lower substrate 11 and an upper substrate 12, both being made of a light-transmissive material, are affixed to each other with a UV-curable, photo-polymer adhesive 13, with a liquid crystal material 15 filled in a space between the substrates. The adhesive 13 contains spacers 14 having a $5\mu\text{m}$ diameter for keeping the distance between the lower substrate 11 and the upper substrate 12 constant.

[0004] In order to dispose the liquid crystal material 15 inside of the adhesive 13 as shown in Fig. 3, one conventional liquid crystal drop method comprises the steps of applying the adhesive 13 on the lower substrate 11 to a thickness of $30\mu\text{m}$ at the perimeter (Fig. 4A), dropping the liquid crystal material 15 to an inner side relative to the adhesive 13 (Fig. 4B), superposing the upper substrate 12 above the lower substrate 11 and pressing the substrates until the gap between both substrates becomes $5\mu\text{m}$ (Fig. 4C), and curing the adhesive 13 by irradiating ultraviolet light, whereby the liquid crystal display device is completed (Fig. 4D).

[0005] The process of affixing the two substrates together in the above conventional method will be described in more detail with reference to Figs. 5A through 5F.

[0006] First, a lower substrate 11, on which an adhesive 13 of UV-curable photo-polymer has been applied to a thickness of $30\mu\text{m}$ at the perimeter, after which the resulting cavity has been filled with a liquid crystal material 15, is placed on a table 17 movable in a horizontal direction, and the entire lower surface of the substrate 11 is fixedly held by vacuum suction with a suction-holding mechanism 18 (Fig. 5A). Next, an upper substrate 12 is positioned at a distance opposite the lower substrate 11 and the entire upper surface of the substrate 12 is fixedly held by vacuum suction with a suction-holding mechanism 19 (Fig. 5B). The upper substrate 12 is then lowered so that the distance between the upper substrate 12 and the lower substrate 11 is 1mm, and the vacuum chamber C is closed (Fig. 5C). Next, the table 17 on which the lower substrate 11 is placed is moved in a horizontal direction for adjusting the positional relationship between the upper substrate 12 and the lower substrate 11, and a vacuum is drawn within the vacuum chamber C (Fig. 5D). The upper substrate 12 is then lowered so that it contacts the adhesive 13 or the liquid crystal material 15 and is further pressed thereon until the distance between the upper and lower substrates

becomes $5\mu\text{m}$, whereby the upper substrate 12 is affixed to the lower substrate 11 through the adhesive 13 (Fig. 5E). After that, ultraviolet rays 16 are irradiated for curing the adhesive 13 (Fig. 5F), by which the affixing of upper and lower substrates is completed.

[0007] In the above described conventional method, after the positions of the upper substrate 12 and the lower substrate 11 are adjusted relative to each other with the 1mm spacing therebetween, the upper substrate 12 is lowered nearly 1mm to contact the adhesive 13 and the liquid crystal material 15, and is further pressed in a vertical direction. There was thus the problem that the upper substrate 12 is sometimes misaligned relative to the lower substrate 11 during it is lowered toward and pressed onto the lower substrate 11.

[0008] In view of the above described problem in the prior art method, an object of the present invention is to provide a method of manufacturing liquid crystal display devices with which misalignment between an upper and lower substrates when affixing them together is prevented, whereby defects in resulting display panels such as unevenness in image can be eliminated.

[0009] To accomplish the above object, the present invention provides a method of manufacturing a liquid crystal display device comprising the steps of positioning a first substrate on which an adhesive has been applied and a liquid crystal material has been deposited within a vacuum chamber and holding a lower surface of the first substrate fixedly by vacuum suction; a second substrate of which upper surface is held fixedly by vacuum suction is brought opposite to the first substrate at a predetermined distance therefrom; moving one or both of the first and second substrates closer to each other for bringing the second substrate into contact with the adhesive or the liquid crystal material on the first substrate; moving both of the first and second substrates relative to each other in a direction parallel to the substrate surface for position alignment; and moving one or both of the first and second substrates for pressing the substrates to each other, whereby both substrates are affixed together.

[0010] In this method, since the position alignment of the first and second substrates is performed after the second substrate has been brought into contact with the adhesive or the liquid crystal material on the first substrate, both substrates need to be moved only a small distance when adjusting their positions relative to each other, whereby the two substrates are hardly misaligned relative to each other when they are affixed together. Defects such as unevenness in image displayed on a resulting display panel can be accordingly eliminated.

[0011] The present invention also provides a method of manufacturing a liquid crystal display device comprising the steps of positioning a first substrate on which an adhesive has been applied and a liquid crystal material has been deposited within a vacuum chamber and holding a lower surface of the first substrate fixedly by vacuum suction; a second substrate of which upper surface

is held fixedly by vacuum suction is brought opposite to the first substrate at a predetermined distance therefrom; moving one or both of the first and second substrates closer to each other until they are located at a predetermined spacing; moving both of the first and second substrates relative to each other in a direction parallel to the substrate surface for preliminary position alignment; moving one or both of the first and second substrates closer to each other for bringing the second substrate into contact with the adhesive or the liquid crystal material on the first substrate; moving both of the first and second substrates relative to each other in a direction parallel to the substrate surface for position alignment; and moving one or both of the first and second substrates for pressing the substrates to each other, whereby both substrates are affixed together.

[0012] Misalignment between both substrates when affixing them together can be prevented and defects such as unevenness in image displayed on a resulting display panel can be accordingly eliminated, too, with this method. Moreover, since the substrates need to be moved only a small distance when adjusting their positions relative to each other owing to the preliminary positional alignment, the melting-in of the adhesive into the liquid crystal material can be suppressed.

[0013] If, in the step of bringing the second substrate into contact with the adhesive or the liquid crystal material on the first substrate, the second substrate is positioned at a height so that a minute gap is created between the second substrate and the adhesive on the first substrate, it is prevented that both surfaces are stuck together with the adhesive before the position alignment.

[0014] If a resilient member is interposed between the first substrate and a mechanism for holding the first substrate by vacuum suction, it helps the first substrate to conform to the configuration of the second substrate, whereby the spacing between the first and second substrates can be precisely controlled. In such case, the first substrate should preferably be released from the suction hold after the first and second substrates have been affixed together, whereby both of the substrates are held by the suction-holding mechanism for the second substrate, and the flatness of both substrates can be highly maintained.

[0015] If, after the first and second substrates have been affixed together, the first substrate is released from the suction hold, and both substrates are tacked together with an UV-curable adhesive after the vacuum chamber is opened and exposed to atmospheric air, it is reliably prevented that both substrates are misaligned relative to each other after being affixed together.

[0016] Also, if, the first and second substrates are tacked together with an UV-curable adhesive after they are affixed together, and thereafter the first substrate is released from the suction hold, and the vacuum chamber is opened and exposed to atmospheric air, it is reliably prevented that both substrates are misaligned rel-

ative to each other after being affixed together.

[0017] If at least one of the first and second substrates is positioned with the use of a location mechanism, the substrate can be reliably fixed in position.

[0018] Preferred embodiments of the present invention will be described with reference to the accompanying drawings, in which:

Figs. 1A-1E are schematic sectional views showing the production steps in sequence according to the first embodiment of the method of manufacturing liquid crystal display devices of the present invention;

Figs. 2A-2F are schematic sectional views showing the production steps in sequence according to the second embodiment of the method of manufacturing liquid crystal display devices of the present invention;

Fig. 3 is a schematic sectional view showing the structure of a liquid crystal display device;

Figs. 4A-4D are schematic sectional views showing the production steps in sequence according to a liquid crystal drop method for manufacturing liquid crystal display devices; and

Figs. 5A-5F are schematic sectional views showing the production steps in sequence according to a conventional method of manufacturing liquid crystal display devices.

[0019] A first embodiment of the method of manufacturing liquid crystal display devices according to the present invention will be hereinafter described with reference to Figs. 1A through 1E.

[0020] In step (a), a lower substrate 3 made of a light-transmissive material, on which an adhesive 1 of UV-curable photo-polymer has been applied to a thickness of 30 μ m at the perimeter, after which the resulting cavity has been filled with a liquid crystal material 2, is placed on a table 4 movable in a horizontal direction within a vacuum chamber C, and the entire lower surface of the substrate 3 is fixedly held by vacuum suction with a suction-holding mechanism 5 (Fig. 1A).

[0021] Next, in step (b), the vacuum chamber C is closed and a vacuum is drawn therein, and an upper substrate 6 made of a light-transmissive material, of which entire upper surface is fixedly held by vacuum suction with a suction-holding mechanism 7, is lowered in a vertical direction so that the upper substrate 6 contacts the adhesive 1 and/or the liquid crystal material 2 (Fig. 1B).

[0022] In step (c), the table 4 on which the lower substrate 3 is placed is then moved in a horizontal direction for adjusting the positional relationship between the upper substrate 6 and the lower substrate 3 (Fig. 1C).

[0023] Next, in step (d), the suction-holding mechanism 7 descends in a vertical direction for affixing the upper substrate 6 onto the lower substrate 3 through the adhesive 1, and presses the upper substrate 6 until the

distance between the upper and lower substrates becomes $5\mu\text{m}$ (Fig. 1D).

[0024] After that, in step (e), the upper and lower substrates are taken out from the vacuum chamber C, and ultraviolet rays 8 are irradiated for curing the adhesive 1, by which the affixing of upper and lower substrates is completed (Fig. 1E).

[0025] According to this method, the positioning precision of two opposite spaced substrate 3, 6 can be maintained lower than $1\mu\text{m}$, by which unevenness in image displayed on a resulting display panel can be eliminated.

[0026] The distance between the upper and lower substrate 3, 6 when pressed to each other in the above described step (d) can be variously set in accordance with the diameter of spacers contained in the adhesive 1.

[0027] Next, a second embodiment of the method of manufacturing liquid crystal display devices according to the present invention will be described with reference to Figs. 2A through 2F.

[0028] In step (a), a lower substrate 3 made of a light-transmissive material, on which an adhesive 1 of UV-curable photo-polymer has been applied to a thickness of $30\mu\text{m}$ at the perimeter, after which the resulting cavity has been filled with a liquid crystal material 2, is placed on a table 4 movable in a horizontal direction within a vacuum chamber C, and the entire lower surface of the substrate 3 is fixedly held by vacuum suction with a suction-holding mechanism 5 (Fig. 2A).

[0029] Next, in step (b), the vacuum chamber C is closed and a vacuum is drawn therein, and an upper substrate 6 made of a light-transmissive material, of which entire upper surface is fixedly held by vacuum suction with a suction-holding mechanism 7, is lowered so that the distance between the upper substrate 6 and the lower substrate 3 is 1mm . The table 4 on which the lower substrate 3 is placed is moved in a horizontal direction for preliminary alignment between the upper substrate 6 and the lower substrate 3 (Fig. 2B).

[0030] In step (c), the suction-holding mechanism 7 is lowered so that the upper substrate 6 contacts the adhesive 1 and/or the liquid crystal material 2 (Fig. 2C).

[0031] Next, in step (d), the table 4 on which the lower substrate 3 is placed is moved in a horizontal direction for adjusting the positional relationship between the upper substrate 6 and the lower substrate 3 (Fig. 2D).

[0032] In step (e), the suction-holding mechanism 7 descends in a vertical direction for affixing the upper substrate 6 onto the lower substrate 3 through the adhesive 1, and presses the upper substrate 6 until the distance between the upper and lower substrates becomes $5\mu\text{m}$ (Fig. 2E).

[0033] After that, in step (f), the upper and lower substrates are taken out from the vacuum chamber C, and ultraviolet rays 8 are irradiated for curing the adhesive 1, by which the affixing of upper and lower substrates is completed (Fig. 2F).

[0034] According to this method, the positioning precision of two opposite spaced substrate 3, 6 can be maintained lower than $1\mu\text{m}$, by which unevenness in image displayed on a resulting display panel can be eliminated. Specifically, owing to the preliminary alignment in step (b), the lower substrate 3 needs to be moved only a small distance when its position is adjusted relative to the upper substrate in step (d). The adhesive 1 can thus be prevented from melting in the liquid crystal material 2, that is caused by movements of the substrates relative to each other.

[0035] The distance between the upper and lower substrate 3, 6 when pressed to each other in the above described step (e) can be variously set in accordance with the diameter of spacers contained in the adhesive 1.

[0036] In order to prevent the upper and lower substrates 3, 6 from being stuck together by the adhesive 1 in which case their positions cannot be adjusted, there may be provided a mechanism by which, in the step of bringing the upper substrate 6 into contact with the adhesive 1 or the liquid crystal material 2, the upper substrate 6 is positioned about $100\mu\text{m}$ above the adhesive 1.

[0037] Also, in order to achieve high precision in the spacing control between the upper and lower substrate 3, 6, a resilient member may be interposed between the lower substrate 3 and the suction-holding mechanism 5. In that case, after the affixing of both substrates, the lower substrate 3 should preferably be released from the suction hold and be held fixedly by the suction-holding mechanism 7 for the upper substrate 6. In this way the flatness of upper and lower substrate 3, 6 after they have been affixed together can be highly maintained.

[0038] After the upper and lower substrates 3, 6 have been contacted, both substrates may be held by vacuum suction with the suction-holding mechanism 7 for the upper substrate 6 by releasing the lower substrate 3 from the hold of the suction-holding mechanism 5, and with the substrates exposed to atmospheric air by opening the vacuum chamber C, they may be provisionally tacked together with the UV-curable adhesive by irradiating ultraviolet light, so that the upper and lower substrates will not be misaligned relative to each other after they have been affixed together.

[0039] Alternatively, immediately after the upper and lower substrates 3, 6 have been affixed together, they may be provisionally tacked together with the UV-curable adhesive by irradiating ultraviolet light before opening the vacuum chamber.

[0040] In addition, a location mechanism may be further provided for restricting the position of either or both of the upper and lower substrates 3, 6, whereby the hold of the substrate can be made more reliable.

[0041] As described above, according to the method of manufacturing liquid crystal display devices of the present invention, the position of the upper substrate is adjusted in relation to the lower substrate after the upper

substrate has been brought into contact with the adhesive or the liquid crystal material on the lower substrate. In this way, substrates need not be moved a long distance after they have been positioned to each other, and therefore they will hardly be misaligned after being affixed together. Defects in resulting display panels such as unevenness in image can be thus eliminated.

[0042] Alternatively, the substrates may be brought in proximity with each other with a predetermined spacing therebetween, where preliminary alignment between the two substrates is performed. In this way, when positioning the both substrates to each other later, they need to be moved only a small distance, whereby the melting-in of the adhesive into the liquid crystal material can be suppressed.

Claims

1. A method of manufacturing a liquid crystal display device comprising the steps of

positioning a first substrate on which an adhesive has been applied and a liquid crystal material has been deposited within a vacuum chamber and holding a lower surface of the first substrate fixedly by vacuum suction;

a second substrate of which upper surface is held fixedly by vacuum suction is brought opposite to the first substrate at a predetermined distance therefrom;

moving one or both of the first and second substrates closer to each other for bringing the second substrate into contact with the adhesive or the liquid crystal material on the first substrate; moving both of the first and second substrates relative to each other in a direction parallel to the substrate surface for position alignment; and

moving one or both of the first and second substrates for pressing the substrates to each other, whereby both substrates are affixed together.

2. A method of manufacturing a liquid crystal display device comprising the steps of

positioning a first substrate on which an adhesive has been applied and a liquid crystal material has been deposited within a vacuum chamber and holding a lower surface of the first substrate fixedly by vacuum suction;

a second substrate of which upper surface is held fixedly by vacuum suction is brought opposite to the first substrate at a predetermined distance therefrom;

moving one or both of the first and second substrates closer to each other until they are locat-

ed at a predetermined spacing; moving both of the first and second substrates relative to each other in a direction parallel to the substrate surface for preliminary position alignment;

moving one or both of the first and second substrates closer to each other for bringing the second substrate into contact with the adhesive or the liquid crystal material on the first substrate; moving both of the first and second substrates relative to each other in a direction parallel to the substrate surface for position alignment; and

moving one or both of the first and second substrates for pressing the substrates to each other, whereby both substrates are affixed together.

3. The method of manufacturing a liquid crystal display device according to claim 1 or 2 wherein in the step of bringing the second substrate into contact with the adhesive or the liquid crystal material on the first substrate, the second substrate is positioned at a height where a minute gap exists between the second substrate and the adhesive on the first substrate.

4. The method of manufacturing a liquid crystal display device according to claim 1 or 2 wherein a resilient member is interposed between the first substrate and a mechanism for holding the first substrate by vacuum suction.

5. The method of manufacturing a liquid crystal display device according to claim 4 wherein the first substrate is released from the suction hold after the first and second substrates have been affixed together.

6. The method of manufacturing a liquid crystal display device according to claim 1 or 2 wherein the first substrate is released from the suction hold after the first and second substrates have been affixed together, the vacuum chamber is opened and exposed to atmospheric air, and both substrates are tacked together with a UV-curable adhesive.

7. The method of manufacturing a liquid crystal display device according to claim 1 or 2 wherein the first and second substrates are tacked together with a UV-curable adhesive after they are affixed together, and thereafter the first substrate is released from the suction hold, and the vacuum chamber is opened and exposed to atmospheric air.

8. The method of manufacturing a liquid crystal display device according to claim 1 or 2 wherein at least one of the first and second substrates is posi-

tioned with the use of a location mechanism.

9. A method of manufacturing a liquid crystal display device in a system wherein a substrate is affixed to another substrate on which an adhesive and liquid crystal material have been applied within a vacuum chamber, characterized in that one or both of the substrates is/are moved until one substrate contacts the adhesive on the other substrate, after which the substrates are moved relative to each other for position alignment, and the substrates are pressed to each other so that they are affixed together.
10. A method of manufacturing a liquid crystal display device in a system wherein a substrate is affixed to another substrate on which an adhesive and liquid crystal material have been applied within a vacuum chamber, characterized in that the substrates are brought into close proximity to each other, where the substrates are preliminarily aligned to each other, and one or both of the substrates is/are moved until one substrate contacts the adhesive on the other substrate, after which the substrates are moved relative to each other for position alignment, and the substrates are pressed to each other so that they are affixed together.

5

10

15

20

25

30

35

40

45

50

55

Fig. 1 A

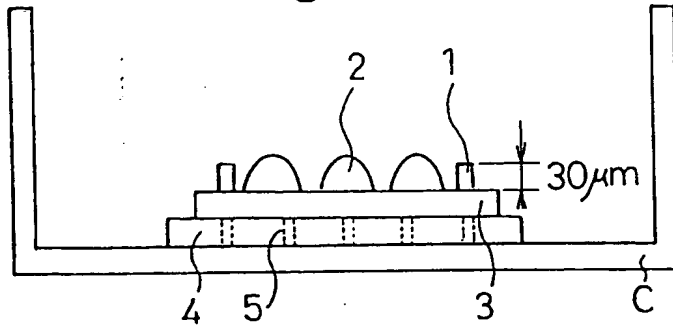

Fig. 1 B

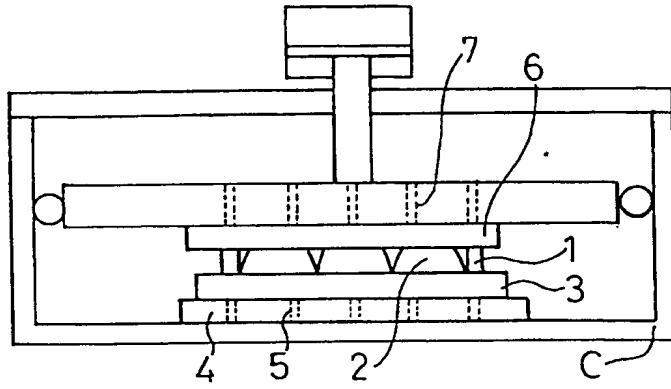

Fig. 1 C

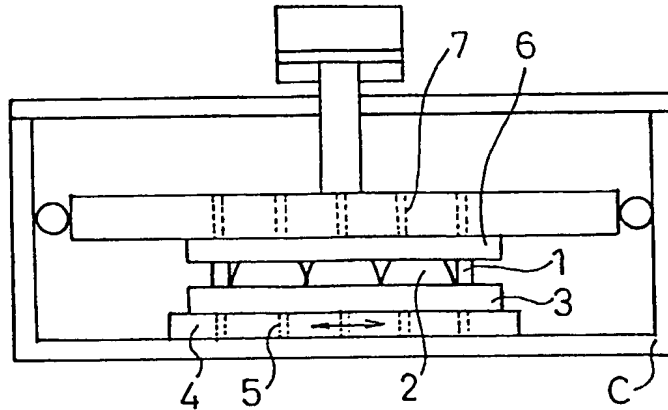

Fig. 1 D

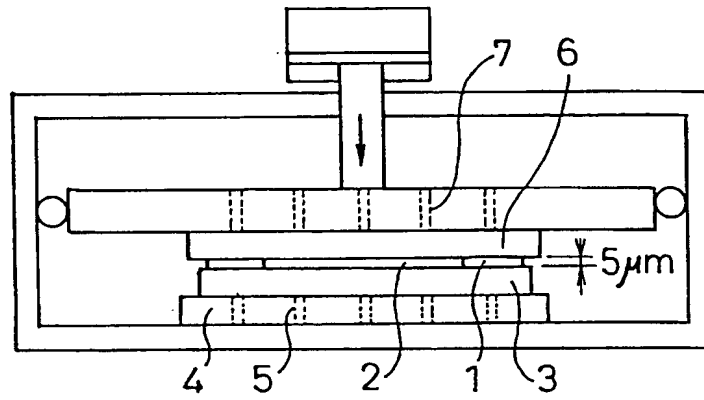

Fig. 1 E

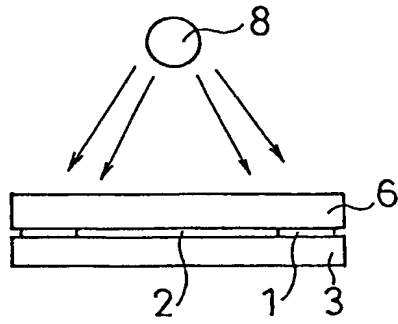

Fig. 2 A

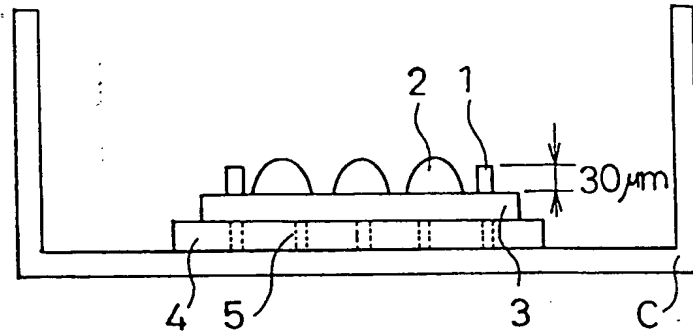

Fig. 2 B

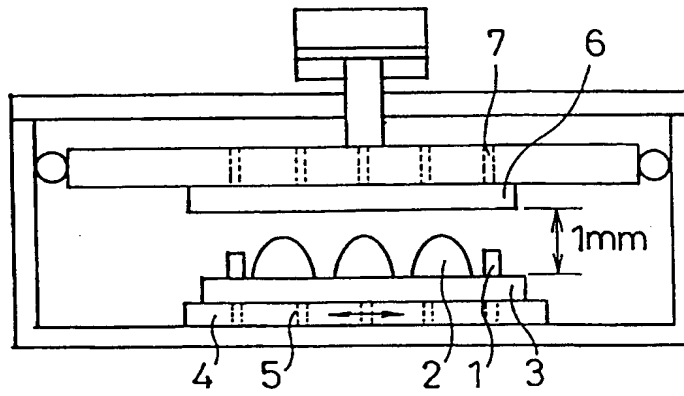

Fig. 2 C

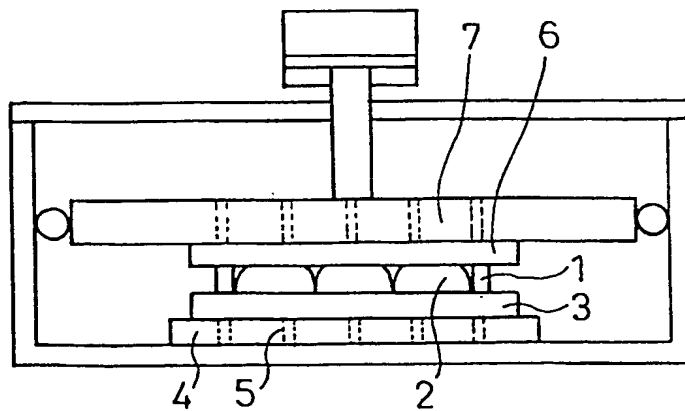

Fig. 2 D

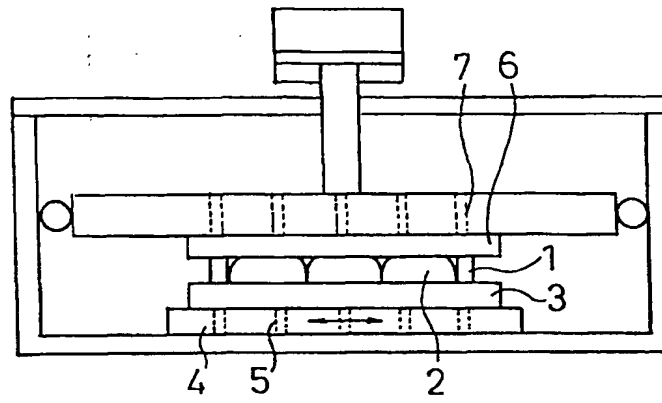

Fig. 2 E

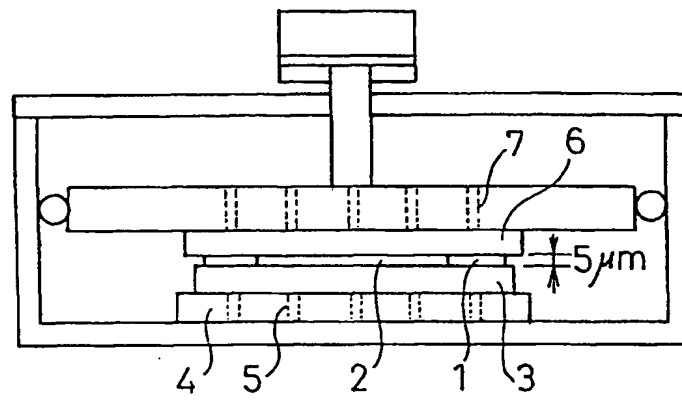

Fig. 2 F

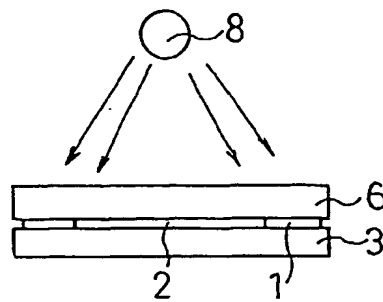

Fig. 3

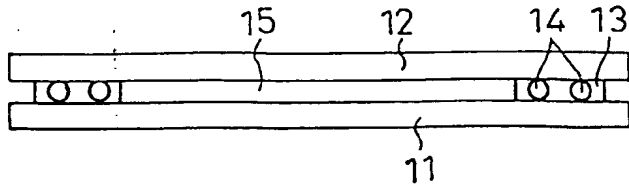

Fig. 4 A

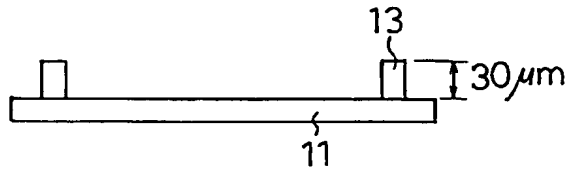

Fig. 4 B

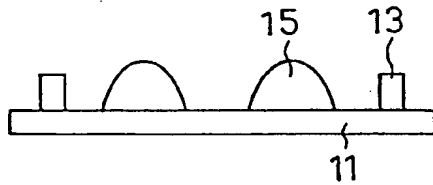

Fig. 4 C

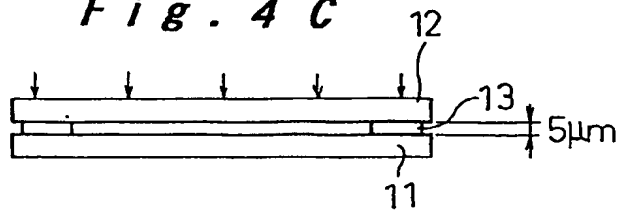
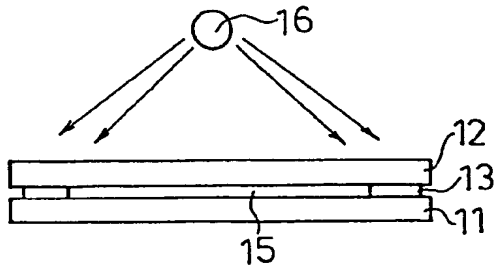

Fig. 4 D



Prior Art
Fig. 5A

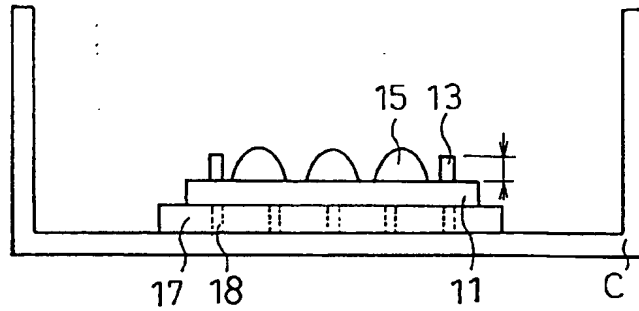

Fig. 5B

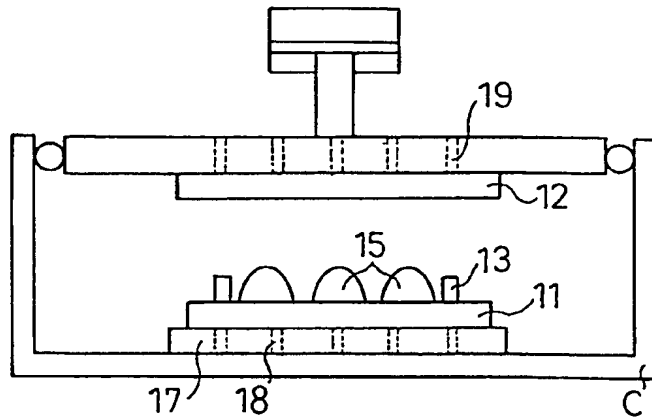

Fig. 5C

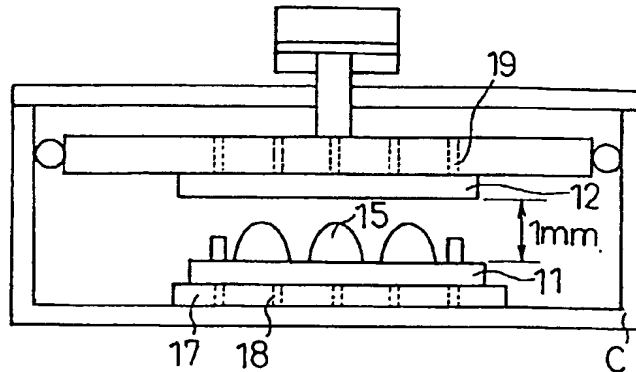

Fig. 5 D

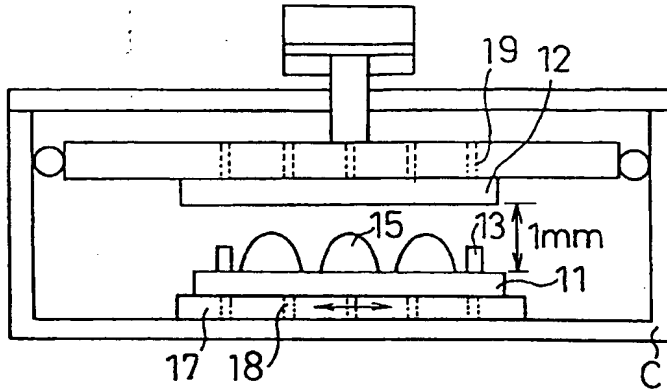

Fig. 5 E

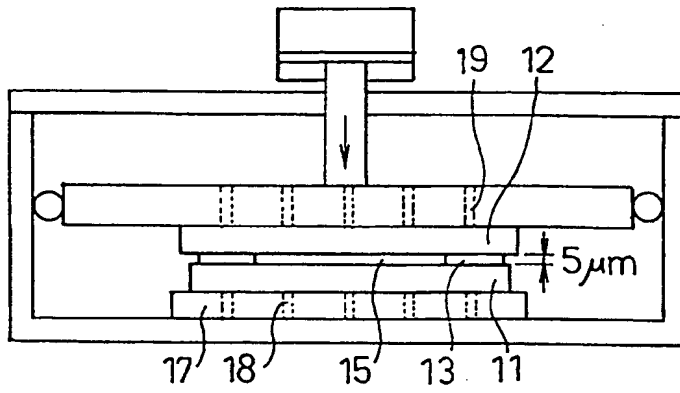

Fig. 5 F

